

MEDIUM POWER AMPLIFIER

ADVANCE DATA

- SILICON EPITAXIAL PLANAR PNP TRANSISTORS
- MINIATURE PLASTIC PACKAGE FOR APPLICATION IN SURFACE MOUNTING CIRCUITS
- GENERAL PURPOSE MAINLY INTENDED FOR USE IN MEDIUM POWER INDUSTRIAL APPLICATION AND FOR AUDIO AMPLIFIER OUTPUT STAGE
- NPN COMPLEMENTS ARE BSP40, BSP41, BSP42 AND BSP43 RESPECTIVELY

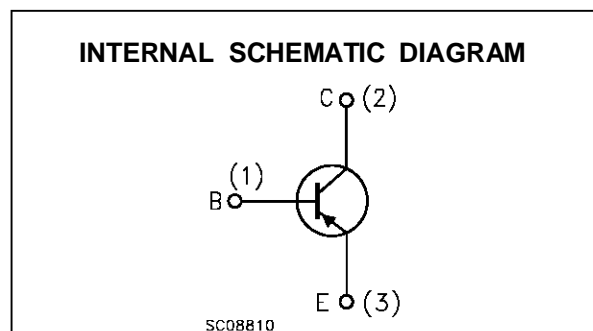
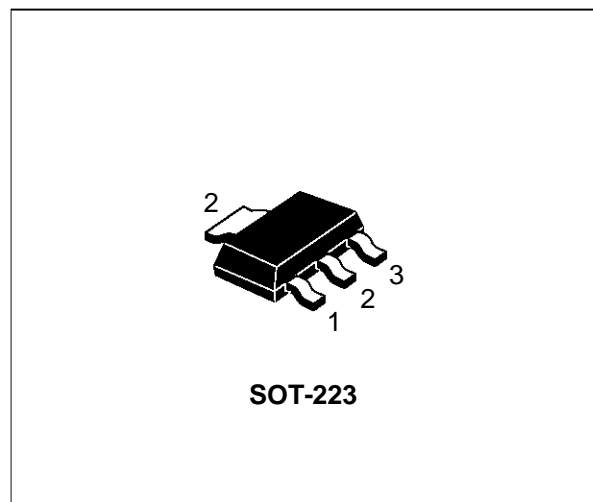

ABSOLUTE MAXIMUM RATINGS

Symbol	Parameter	Value		Unit
		BSP30/BSP31	BSP32/BSP33	
V_{CBO}	Collector-Base Voltage ($I_E = 0$)	-70	-90	V
V_{CEO}	Collector-Emitter Voltage ($I_B = 0$)	-60	-80	V
V_{CES}	Collector-Emitter Voltage ($R_{BE} = 1K\Omega$)	-70	-90	V
V_{EBO}	Emitter-Base Voltage ($I_C = 0$)	-5		V
I_C	Collector Current	-1		A
I_B	Base Current	-0.1		A
P_{tot}	Total Dissipation at $T_c = 25^\circ C$	2		W
T_{stg}	Storage Temperature	-65 to 150		$^\circ C$
T_j	Max. Operating Junction Temperature	150		$^\circ C$

BSP30/31/32/33

THERMAL DATA

$R_{thj-amb}$ •	Thermal Resistance Junction-Ambient	Max	62.5	$^{\circ}\text{C}/\text{W}$
$R_{thj-tab}$ •	Thermal Resistance Junction-Collector Tab	Max	8	$^{\circ}\text{C}/\text{W}$

• Mounted on a ceramic substrate area = 30 x 35 x 0.7 mm

ELECTRICAL CHARACTERISTICS ($T_{case} = 25^{\circ}\text{C}$ unless otherwise specified)

Symbol	Parameter	Test Conditions	Min.	Typ.	Max.	Unit
I_{CBO}	Collector Cut-off Current ($I_E = 0$)	$V_{CB} = -60\text{ V}$ $V_{CB} = -60\text{ V}$ $T_j = 150^{\circ}\text{C}$			-100 -50	nA μA
$V_{(BR)CBO}$	Collector-Base Breakdown Voltage ($I_E = 0$)	$I_C = -100\ \mu\text{A}$ for BSP30/BSP31 for BSP32/BSP33	-70 -90			V V
$V_{(BR)CEO}^*$	Collector-Emitter Breakdown Voltage ($I_B = 0$)	$I_C = -10\text{ mA}$ for BSP30/BSP31 for BSP32/BSP33	-60 -80			V V
$V_{(BR)CES}$	Collector-Emitter Breakdown Voltage ($V_{BE} = 0$)	$I_C = -10\ \mu\text{A}$ for BSP30/BSP31 for BSP32/BSP33	-70 -90			V V
$V_{(BR)EBO}$	Emitter-Base Breakdown Voltage ($I_C = 0$)	$I_C = -10\ \mu\text{A}$	-5			V
$V_{CE(sat)}^*$	Collector-Emitter Saturation Voltage	$I_C = -150\text{ mA}$ $I_B = -15\text{ mA}$ $I_C = -500\text{ mA}$ $I_B = -50\text{ mA}$			-0.25 -0.5	V V
$V_{BE(sat)}^*$	Base-Emitter Saturation Voltage	$I_C = -150\text{ mA}$ $I_B = -15\text{ mA}$ $I_C = -500\text{ mA}$ $I_B = -50\text{ mA}$			-1 -1.2	V V
h_{FE}^*	DC Current Gain	for BSP30/BSP31 $I_C = -100\ \mu\text{A}$ $V_{CE} = -5\text{ V}$ $I_C = -100\text{ mA}$ $V_{CE} = -5\text{ V}$ $I_C = -500\text{ mA}$ $V_{CE} = -5\text{ V}$ for BSP32/BSP33 $I_C = -100\ \mu\text{A}$ $V_{CE} = -5\text{ V}$ $I_C = -100\text{ mA}$ $V_{CE} = -5\text{ V}$ $I_C = -500\text{ mA}$ $V_{CE} = -5\text{ V}$	10 40 30		120	
f_T	Transition Frequency	$I_C = -50\text{ mA}$ $V_{CE} = -10\text{ V}$ $f = 35\text{ MHz}$	100			MHz
C_{CBO}	Collector-Base Capacitance	$I_E = 0$ $V_{CB} = -10\text{ V}$ $f = 1\text{ MHz}$			20	pF
C_{EBO}	Emitter-Base Capacitance	$I_C = 0$ $V_{EB} = -0.5\text{ V}$ $f = 1\text{ MHz}$			120	pF
t_{on}	Turn-on Time	$I_C = -100\text{ mA}$ $I_{B1} = -I_{B2} = -5\text{ mA}$			500	ns
t_{off}	Turn-off Time				650	ns

* Pulsed: Pulse duration = 300 μs , duty cycle $\leq 1.5\%$

SOT223 MECHANICAL DATA

DIM.	mm			mils		
	MIN.	TYP.	MAX.	MIN.	TYP.	MAX.
a	2.27	2.3	2.33	89.4	90.6	91.7
b	4.57	4.6	4.63	179.9	181.1	182.3
c	0.2	0.4	0.6	7.9	15.7	23.6
d	0.63	0.65	0.67	24.8	25.6	26.4
e1	1.5	1.6	1.7	59.1	63	66.9
e4			0.32			12.6
f	2.9	3	3.1	114.2	118.1	122.1
g	0.67	0.7	0.73	26.4	27.6	28.7
l1	6.7	7	7.3	263.8	275.6	287.4
l2	3.5	3.5	3.7	137.8	137.8	145.7
L	6.3	6.5	6.7	248	255.9	263.8

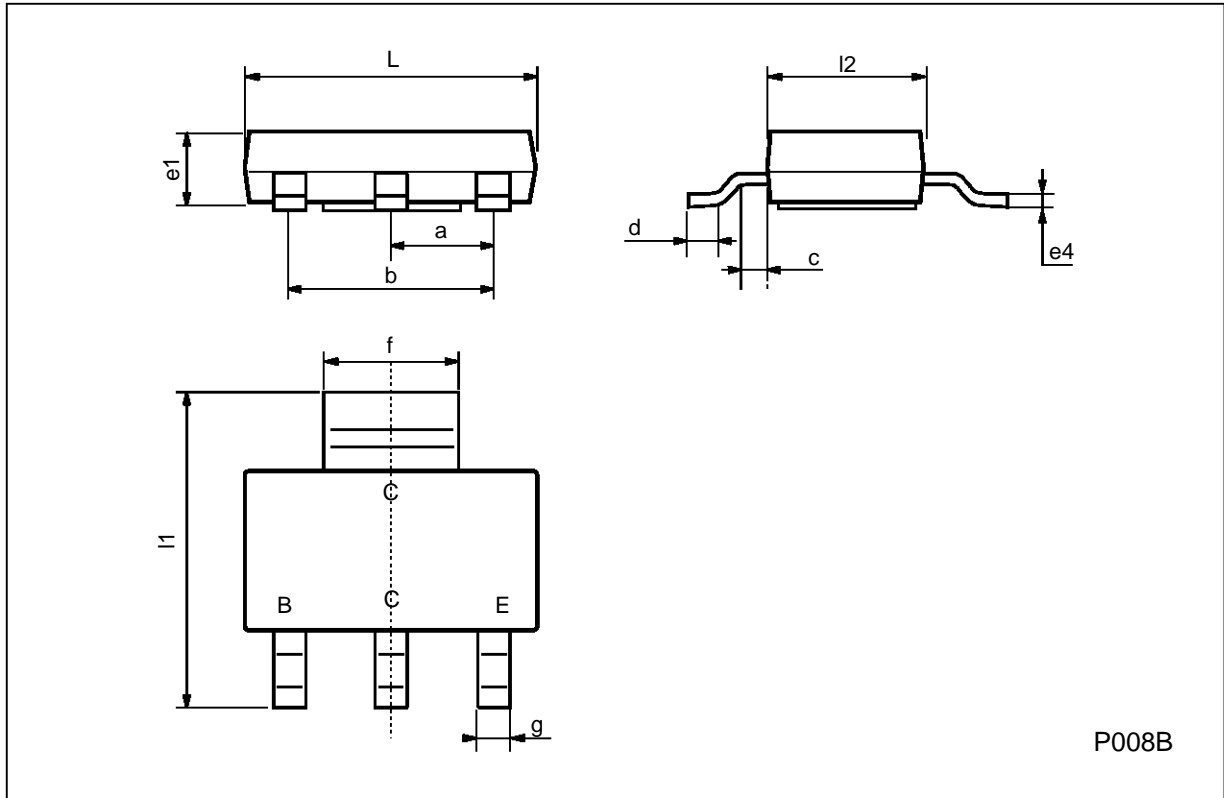

Information furnished is believed to be accurate and reliable. However, SGS-THOMSON Microelectronics assumes no responsibility for the consequences of use of such information nor for any infringement of patents or other rights of third parties which may result from its use. No license is granted by implication or otherwise under any patent or patent rights of SGS-THOMSON Microelectronics. Specifications mentioned in this publication are subject to change without notice. This publication supersedes and replaces all information previously supplied. SGS-THOMSON Microelectronics products are not authorized for use as critical components in life support devices or systems without express written approval of SGS-THOMSON Microelectronics.

© 1995 SGS-THOMSON Microelectronics - All Rights Reserved

SGS-THOMSON Microelectronics GROUP OF COMPANIES

Australia - Brazil - France - Germany - Hong Kong - Italy - Japan - Korea - Malaysia - Malta - Morocco - The Netherlands - Singapore - Spain - Sweden - Switzerland - Taiwan - Thailand - United Kingdom - U.S.A